

TRAKROL®

SPECIAL-DUTY CAM FOLLOWER BEARINGS



EMERSON POWER TRANSMISSION

**Now With
Black Oxide
Coating**

**Designed and Built for Longer Life
Under Combination Radial and Thrust
Loads... More Contaminated Applications.**



McGILL®
PRECISION BEARINGS

TRAKROL®

Special-Duty Cam Follower Bearings

TRAKROL Bearings feature precision ball bearings or tapered roller bearings to provide longer operating life under combination radial and thrust loads. Sizes 1 1/2" – 2 3/4" O.D. (or point diameters on VCF Series) feature ball bearing construction. Sizes 3" - 8" O.D. feature tapered roller bearing construction.

Bearings are double-sealed for dirty or contaminated environments, or where reduced maintenance is required.

PRECISION BALL BEARING CONSTRUCTION

- 1. Heavy Walled Outer Housing**
 - Hardened to resist wear or fracture
- 2. Precision Ball Bearing Inserts**
 - Allows for thrust loads
 - Large grease reservoir for longer life without relubrication
 - High-speed capability
- 3. Special Sealing**
 - Metal expansion plug provides extra sealing at roller face
- 4. Sealing**
 - Rubber lip seals on ball bearings for improved sealing and grease retention
- 5. Extra Sealing**
 - NYLAPLATE® Seal for extra protection
 - Only from McGill

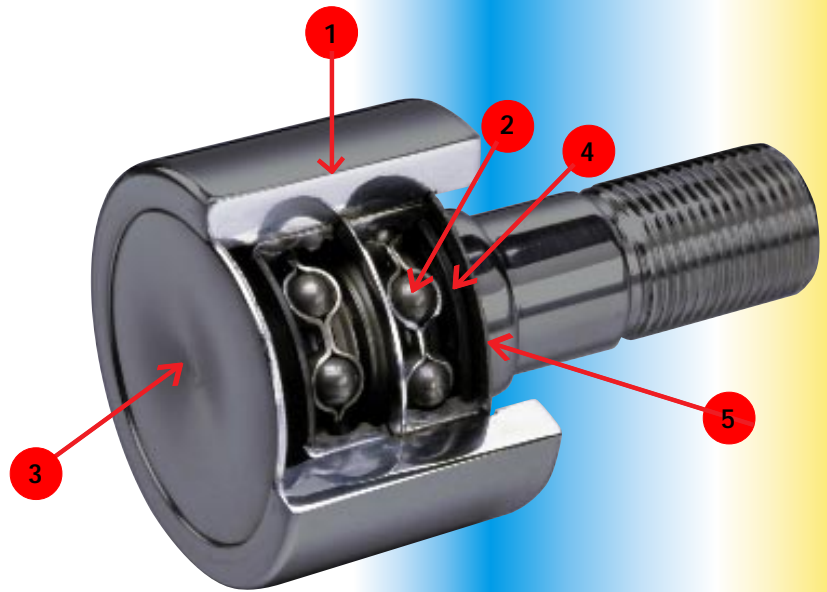

TAPERED ROLLER BEARING CONSTRUCTION

- 1. Heavy Walled Outer Housing**
 - Hardened to resist wear or fracture
- 2. Tapered Roller Bearing Insert**
 - Allows for thrust loads
 - Large grease reservoir for longer life without relubrication
 - High-speed capability
- 3. Special Sealing**
 - Metal expansion plug provides extra sealing at roller face
- 4. Sealing**
 - Rubber lip seals for improved sealing and grease retention

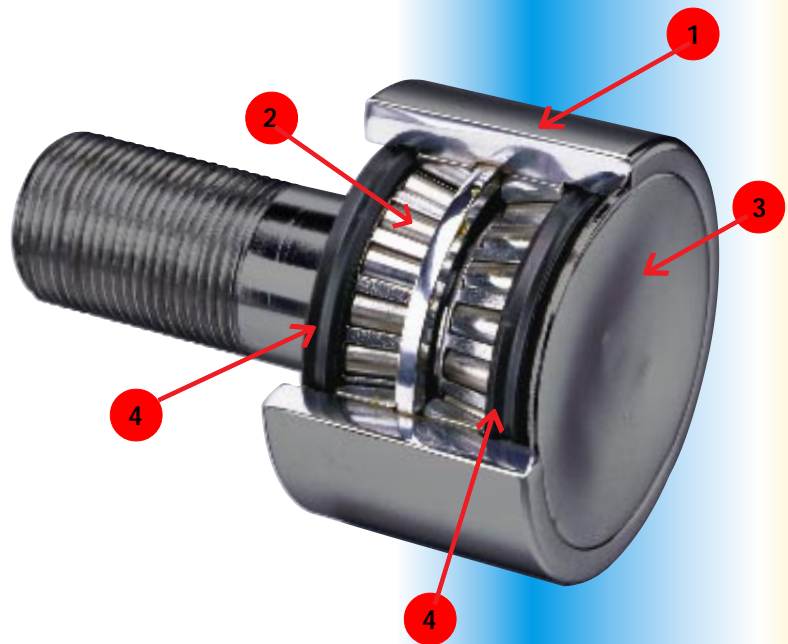

TRAKROL TRAKROL®

Designed a

TRAKROL Bearings from McGill are built with features and performance characteristics not available with needle roller type bearings. McGill offers these special duty TRAKROL Bearings in three different O.D. configurations to cover a wide variety of applications. The standard configurations are:

- VCF Series – V-Groove O.D.
- FCF Series – Flanged O.D.

PCF Series Special-duty cam followers with plain O.D.'s and integral seals

- Similar to CAMROL® Cam Followers but not dimensionally interchangeable



VCF Series Special-duty cam followers with V-groove O.D.'s and integral seals

- Typically used with "V" shaped tracks
- Configuration reduces sediment build-up on tracks



FCF Series Special-duty cam followers with flanged O.D.'s and integral seals

- Popular in side-guide applications
- Thrust load can be applied to flange



© Emerson Power Transmission Manufacturing, L.P. 1998

McGILL

McGILL
PRECISION BEARINGS®

McGILL

Special-Duty Cam Follow

and Developed for Specialized Severe-Duty App

BRG. NO.	ROLLER DIA. (RD)	WIDTH (W)	STUD DIA. (SD) +.000 -.001	MIN. THREAD LENGTH (TL)	FINE THREADS	STUD LENGTH (SL)	HEX SOCKET (H)	SHOULDER OR ENDPLATE DIA. (E)	RADIAL BASIC DYNAMIC RATING (LBS.)	DYNAMIC THRUST LOAD ^① RATING (LBS.)	MAX. STATIC CAPACITY (LBS.)	BEARING TYPE
PCF-1 1/2	1.500	1 3/16	.625	3/4	5/8-18	1 1/2	1/4	3/4	2520	1320	1370	BALL
PCF-1 3/4	1.750	1 3/16	.750	7/8	3/4-16	1 3/4	1/4	1	2520	1320	1370	
PCF-2	2.000	1 11/16	.875	1 1/8	7/8-14	2	3/8	1	3490	1830	2000	
PCF-2 1/4	2.250	1 11/16	.875	1 1/8	7/8-14	2	3/8	1	3490	1830	2000	
PCF-2 1/2	2.500	1 11/16	1.000	1 1/2	1-14	2 1/4	7/16	1 1/4	5120	2680	3120	
PCF-2 3/4	2.750	1 11/16	1.000	1 1/2	1-14	2 1/4	7/16	1 1/4	5120	2680	3120	
PCF-3	3.000	2	1.250	1 3/4	1 1/4-12	2 1/2	7/16	1 3/4	14300	5790	16000	TAPERED ROLLER
PCF-3 1/4	3.250	2	1.250	1 3/4	1 1/4-12	2 1/2	7/16	1 3/4	14300	5790	16000	
PCF-3 1/2	3.500	2	1.250	1 3/4	1 1/4-12	2 3/4	7/16	1 3/4	14300	5790	16000	
PCF-4	4.000	2	1.250	1 3/4	1 1/4-12	2 3/4	7/16	1 3/4	14300	5790	16000	
PCF-4 1/2	4.500	2	1.250	1 3/4	1 1/4-12	2 3/4	7/16	1 3/4	14300	5790	16000	
PCF-5	5.000	3	2.000	2 1/2	2-12	4 1/2	7/8	3 1/4	35800	13300	40000	
PCF-6	6.000	3	2.500	3 1/4	2 1/2-12	5 1/2	7/8	3 1/4	35800	14200	62000	
PCF-7	7.000	3	2.500	3 1/4	2 1/2-12	5 1/2	7/8	3 1/4	35800	14200	62000	
PCF-8	8.000	3	2.500	3 1/4	2 1/2-12	5 1/2	7/8	3 1/4	35800	14200	62000	

BRG. NO.	OUTSIDE ROLLER DIA. (OD)	POINT DIA. (V)	WIDTH (W)	GROOVE CENTER (C)	STUD DIA. (SD) +.000 -.001	MIN. THREAD LENGTH (TL)	FINE THREADS	STUD LENGTH (SL)	HEX SOCKET	SHOULDER OR ENDPLATE DIA. (E)	RADIAL BASIC DYNAMIC RATING (LBS.)	DYNAMIC THRUST LOAD ^① RATING (LBS.)	MAX. STATIC CAPACITY (LBS.)	BEARING TYPE
VCF-3 1/2	3 1/2	2 1/4	1 11/16	7/8	.875	1 1/8	7/8-14	2	3/8	1	3490	1830	2000	BALL
VCF-4 1/2	4 1/2	3	2	1	1.250	1 3/4	1 1/4-12	2 1/2	7/16	1 3/4	14300	5790	16000	TAPERED ROLLER
VCF-5 1/2	5 1/2	4	2	1	1.250	1 3/4	1 1/4-12	2 3/4	7/16	1 3/4	14300	5790	16000	
VCF-6 1/2	6 1/2	5	3	1 1/2	2.000	2 1/2	2-12	4 1/2	7/8	3 1/4	35800	13300	40000	
VCF-7 1/2	7 1/2	6	3	1 1/2	2.500	3 1/4	2 1/2-12	5 1/2	7/8	3 1/4	35800	14200	62000	
VCF-8 1/2	8 1/2	7	3	1 1/2	2.500	3 1/4	2 1/2-12	5 1/2	7/8	3 1/4	35800	14200	62000	

BRG. NO.	ROLLER DIA. (RD)	FLANGE DIA. (FD)	WIDTH (W)	FLANGE THICKNESS (FT)	STUD DIA. (SD) +.000 -.001	MIN. THREAD LENGTH (TL)	FINE THREADS	STUD LENGTH (SL)	HEX SOCKET (H)	SHOULDER OR ENDPLATE DIA. (E)	RADIAL BASIC DYNAMIC RATING (LBS.)	DYNAMIC THRUST LOAD ^① RATING (LBS.)	MAX. STATIC CAPACITY (LBS.)	BEARING TYPE
FCF-1 1/2	1.500	2 3/16	1 3/16	11/32	.625	3/4	5/8-18	1 1/2	1/4	3/4	2520	1320	1370	BALL
FCF-1 3/4	1.750	2 7/16	1 3/16	11/32	.750	7/8	3/4-16	1 3/4	1/4	1	2520	1320	1370	
FCF-2	2.000	2 11/16	1 11/16	19/32	.875	1 1/8	7/8-14	2	3/8	1	3490	1830	2000	
FCF-2 1/4	2.250	2 15/16	1 11/16	19/32	.875	1 1/8	7/8-14	2	3/8	1	3490	1830	2000	
FCF-2 1/2	2.500	3 3/16	1 11/16	19/32	1.000	1 1/2	1-14	2 1/4	7/16	1 1/4	5120	2680	3120	
FCF-2 3/4	2.750	3 7/16	1 11/16	19/32	1.000	1 1/2	1-14	2 1/4	7/16	1 1/4	5120	2680	3120	
FCF-3	3.000	3 15/16	2	19/32	1.250	1 3/4	1 1/4-12	2 1/2	7/16	1 3/4	14300	5790	16000	TAPERED ROLLER
FCF-3 1/4	3.250	4 3/16	2	19/32	1.250	1 3/4	1 1/4-12	2 1/2	7/16	1 3/4	14300	5790	16000	
FCF-3 1/2	3.500	4 7/16	2	19/32	1.250	1 3/4	1 1/4-12	2 3/4	7/16	1 3/4	14300	5790	16000	
FCF-4	4.000	4 15/16	2	19/32	1.250	1 3/4	1 1/4-12	2 3/4	7/16	1 3/4	14300	5790	16000	
FCF-4 1/2	4.500	5 7/16	2	19/32	1.250	1 3/4	1 1/4-12	2 3/4	7/16	1 3/4	14300	5790	16000	
FCF-5	5.000	5 15/16	3	23/32	2.000	2 1/2	2-12	4 1/2	7/8	3 1/4	35800	13300	40000	
FCF-6	6.000	6 15/16	3	23/32	2.500	3 1/4	2 1/2-12	5 1/2	7/8	3 1/4	35800	14200	62000	
FCF-7	7.000	7 15/16	3	23/32	2.500	3 1/4	2 1/2-12	5 1/2	7/8	3 1/4	35800	14200	62000	
FCF-8	8.000	8 15/16	3	23/32	2.500	3 1/4	2 1/2-12	5 1/2	7/8	3 1/4	35800	14200	62000	

^① Dynamic thrust load rating based on application of a centric, axial load. Fatigue life calculations for combined radial and thrust loading require special considerations and the McGill Engineering Department should be contacted.

er Bearings TRAKROL

Applications

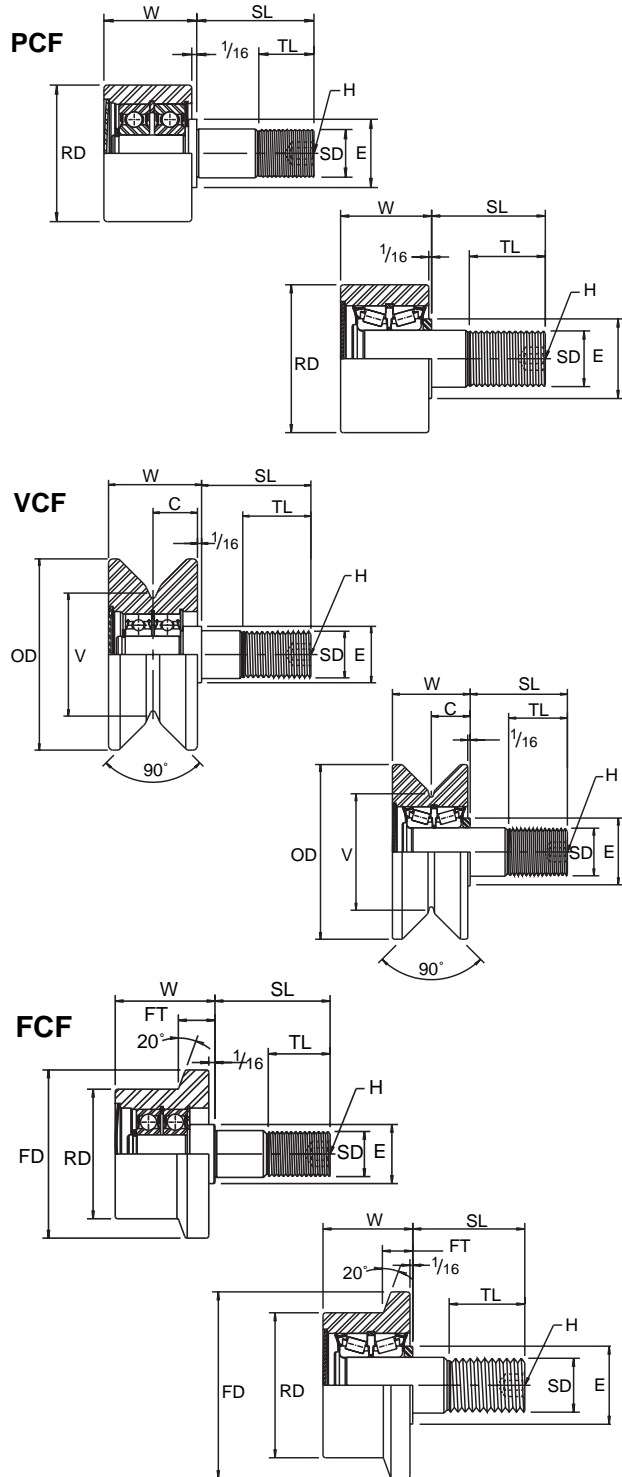

Selection Guide: TRAKROL® vs. CAMROL® Bearings

In some applications, TRAKROL Bearings offer improved performance over needle roller type CAMROL Cam Followers. Consider TRAKROL Bearings for applications involving thrust loads, dirty environments, special roller configurations, and lube-for-life operation.

MATCHING Bearings to Applications:

Application Considerations	CAMROL Bearing	TRAKROL Bearing
Radial Loading	Better ✓	Good
Contamination	Good	Better ✓
Running Accuracy	Better ✓	Good
Lube-for-Life Operation	Good	Better ✓
Thrust Loading	Not Recommended	Good

TRAKROL Track Roller Popular Applications:

- Foundry Equipment
- Steel Mill Equipment
- Automotive Assembly Equipment
- Material Handling Equipment

Interchange Chart

McGill	Osborn*	PCI*
PCF-	PLR-**	PTR-**
VCF-	VLR-	VTR-
FCF-	FLR-	FTR-

* Other manufacturers of comparable products
 ** Each manufacturer uses the same numbering convention i.e. a PCF-1 1/2 interchanges a PLR-1 1/2

Recommended Installation Torque Installation Torque***

Stud Dia.	(in.-lbs.)
.625	325
.750	625
.875	750
1.000	1120
1.250	1720
2.000	2500
2.500	2500

***Values shown are for dry threads. If threads are lubricated, use 1/2 of values shown.



Turn to McGill when you want to do the job right the first time.

CAMROL® Cam Followers

When you want the exact cam followers for your exact needs, come to the company that invented cam followers: McGill. Since 1934 we have expanded our line to include more off-the-shelf designs than any other manufacturer.



SPHERE-ROL® Bearings

For spherical roller bearing applications involving contamination, consider the SPHERE-ROL Bearings. Our 22200 and 22300 Series are available with optional seals and fit inside the standard bearing dimensions.

For ordering information, contact your authorized McGill Distributor or contact McGill Customer Service: Telephone: 219-465-2200
Fax: 219-465-2290

McGILL®
PRECISION BEARINGS

Application Considerations

The proper selection and application of power transmission products and components, including the related area of product safety, is the responsibility of the customer. Operating and performance requirements and potential associated issues will vary appreciably depending upon the use and application of such products and components. The scope of the technical and application information included in this publication is necessarily limited. Unusual operating environments and conditions, lubrication requirements, loading supports, and other factors can materially affect the application and operating results of the products and components, and the customer should carefully review its requirements. Any technical advice or review furnished by Emerson Power Transmission and its divisions with respect to the use of products and components

is given in good faith and without charge, and Emerson assumes no obligation or liability for the advice given, or results obtained, all such advice and review being given and accepted at customer's risk.

Standard Terms and Conditions

For a copy of our Standard Terms and Conditions of Sale, disclaimers of warranty, limitations of liability and remedy, please refer to the current McGill Catalog or contact the McGill Customer Service Center or Distributor nearest you. These terms and conditions of sale, disclaimers and limitations of liability and remedy, apply to any person who may buy, acquire or use McGill bearings referred to herein, including any person who buys from a licensed distributor of McGill/Emerson products.



EMERSON POWER TRANSMISSION
909 N. LAFAYETTE STREET
VALPARAISO, IN 46383-4299 U.S.A.
Telephone 219-465-2200 Fax 219-465-2290
www.emerson-ept.com

McGILL®
PRECISION BEARINGS